

150mm Aluminium Brick Vents

These innovative vents look great and are easy to install. They simply replace a standard brick. Ideal for rangehoods, exhaust fans and general ventilation.

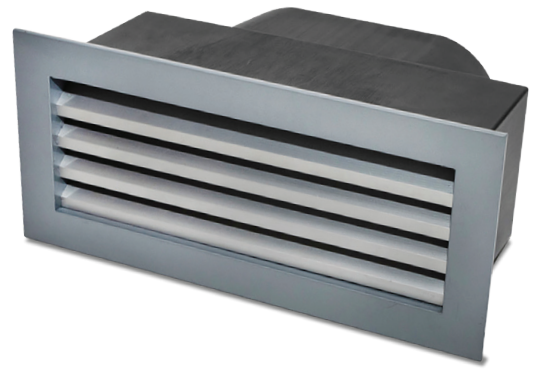

- + BAL-40 rated with insect aluminium mesh
- + Slimline design
- + Ideal for venting exhaust fans under National Construction Code 3.8.7.3
- + Angled blades protect from water penetration
- + Can be used with a fan or for passive ventilation
- + Galvanised steel support frame for reinforced opening
- + Vent face clips into support frame for easy installation
- + 2m x 150mm rectangular flexible foil duct included (kit only)

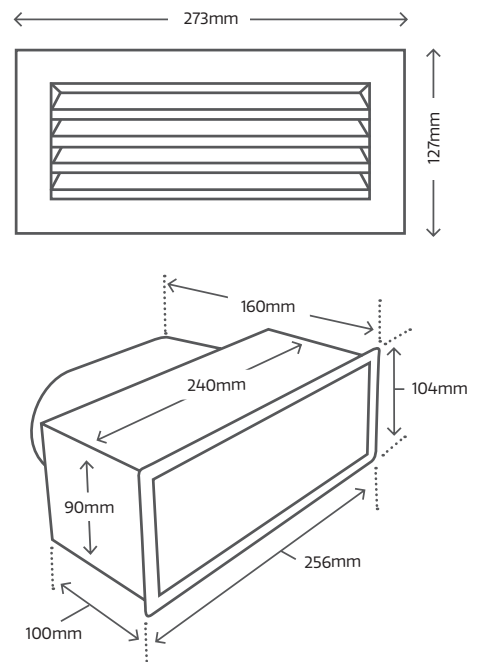

Code	Description	Carton Quantity
BV150	Aluminum Brick Vent 150mm	4
BVK150	Aluminum Brick Vent Kit 150mm	4

