

HEADER BOX FAN

Installation and Maintenance Instructions

Model NO: RF250

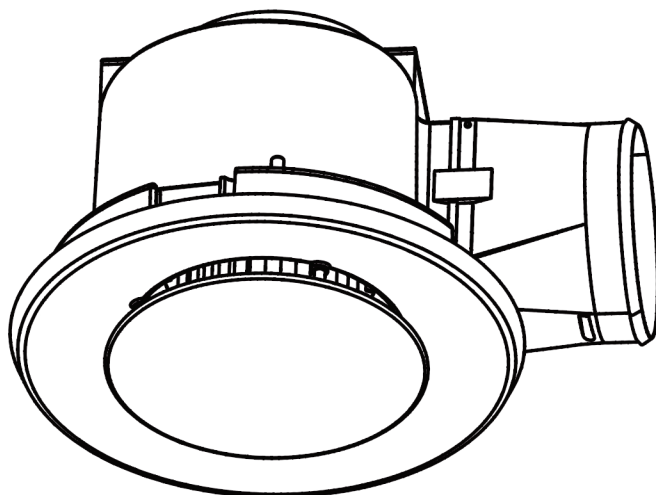

Model	Voltage	Frequency	Power	Duct	Cutout Size
RF250	220 – 240 V	50 Hz	60 W	150mm	295mm Dia

Header Box Fan

Thank you for your selecting this header box exhaust fan. Please read all instructions before commencing installing.

This fan is fitted with a plug. Any interconnecting wiring and switches used or use of another plug must be fitted by a licensed electrician. The plug supplied must be connected to a safety socket.

IMPORTANT

- Use this fan only as described in this manual. Any other use not recommended by the manufacturer may cause fire, electric shock, or injury to persons. If you have any questions, contact the manufacturer or your retailer.
- All wiring must be carried out by a licensed electrician in accordance with all applicable national/local codes and safety standards. Also check with the local council regulation regarding installation of this fan.
- Make sure the power is OFF before installation.
- When locating into the ceiling or wall, do not damage electrical wiring and other hidden utilities.
- The fan must be properly earthed.

Header Box Fan

- The fan must not be connected with ducting used exhaust smoke or fumes from an appliance that uses gas or any other type of fuel.
- Make sure that the building has sufficient air intakes to assure adequate air circulation.
- The fan must be isolated from the power by means of a plug or all-pole disconnection switch with a contact separation of at least 3mm in each pole.
- The power cable must withstand a minimum 10A load.
- The fan is not intended for use by persons (including children) with reduced physical, sensory or mental capabilities, or who lack of experience and knowledge.
- Young children should be supervised by a responsible person to ensure that they do not play with the appliance.
- Make sure there are no loose elements near the ventilator, as they could run the risk of being sucked up by it. If the fan is going to be installed in a duct, check that it is clear of any elements that could be sucked up by the fan.

Header Box Fan

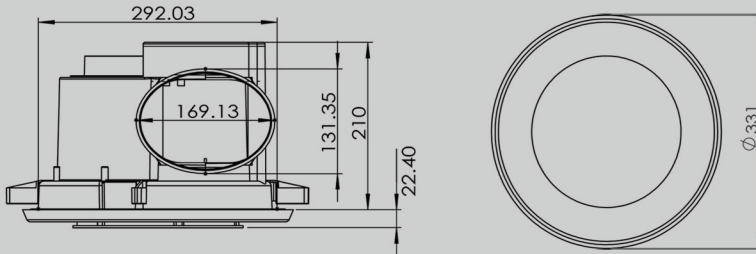

NOTE: Grille assembly shown in diagram is from model RF250

INSTALLATION

This fan must be isolated from the power supply during installation and maintenance.

WARNING: All electrical installations must be carried out by suitably qualified and competent personnel in accordance with all statutory requirements.

- 1 Examine the fan for damage and to ensure that the impeller moves freely.
- 2 Cut vent hole (if required)
Locate a desired location in either the roof or ceiling to and cut out a 295mm diameter vent hole using template provided.
- 3 Ducting
Put one end of the 150mm dia ventilation ducting into the spigot of this fan using duct and/or steel clamps.
- 4 Remove the grille
Pull the grille a little. Squeeze the grille retaining springs and remove the grille from the fan body (if connected).

Header Box Fan

- 5 Wiring (Ensure the power is turned OFF)
Please comply with the local wiring regulations when wiring.

**Wiring
diagram**

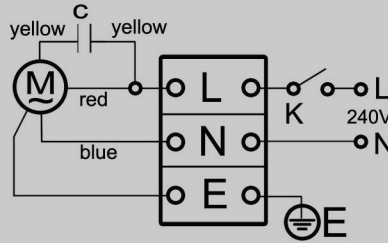

- 6 Securing the unit
Connect spigot to fan body. Then use fast installing clips and screws or other locating means to fasten this unit in the ceiling space tightly.
- 7 Attach the grille to inlet of fan
Put the two retaining springs on the grille into the two slots in the unit and make sure the grille is well fixed.
- 8 Start the fan and ensure there is no excessive vibration, noise or rubbing.

Note: Try to keep redundant wire away from the housing.

Note: The shortest, smooth surface ventilation duct with the least elbows will provide optimum fan performance. Keep the ducting as straight as possible.

Header Box Fan

USE

Running the fan can exhaust air in a quick and efficient way.

Note: Shut off power urgently when any abnormalities occur in operation. Then call your local licensed electrician for inspection or necessary service work.

Note: It is absolutely prohibited to insert finger or object into the impeller for avoiding being injured or damaging the fan.

MAINTENANCE

1. Before cleaning or maintenance, shut off power and disconnect from the mains supply.
2. Prevent the possibility of anyone else connecting the power while cleaning, inspecting or maintaining.
3. All maintenance and repair work must be carried out by a licensed Electrician in accordance with all applicable National / local codes and safety standards.

WARRANTY

- This fan is warranted against defects in manufacturing and workmanship for a period of 3 years. The warranty does not extend to installation of the unit or any associated wiring or any damage caused by installation or wiring.
- The installation must be conducted by a licensed electrician and a suitable certificate of safety is to be issued by the electrician who installed it.
- Warranty claims will be voided unless a certificate of safety can be produced when required, prior to service or repair.
- Note that general wear and tear is not covered by the warranty.
- Proof of purchase of the fan is required.

Header Box Fan

Warranty claims will be voided unless a certificate of safety can be produced when required, prior to service or repair.

The warranty does not cover damages or loss caused by

1. Any consequential losses arising from incorrect installation or operation or maintenance of this product.
2. Any consequential losses arising from incorrect wiring of this product.
3. Any modifications or changes made to the unit, other than those recommended by the manufacturer.

ACCC REQUIRED STATEMENT

Our goods come with guarantees that cannot be excluded under the Australian Consumer Law. You are entitled to our dealers replacing the product in home with parts and labor for a major failure. You are also entitled to have the goods repaired or replaced if the goods fail to be of acceptable quality and the failure does not amount to a major failure.

LIST OF PARTS SUPPLIED

Header box exhaust fan body	1 piece
Main Grille	1 piece
Installation instruction	1 piece
Power cable with plug (applied)	1 set

If you have any queries about the products, please contact our after sales service or local dealer.

We reserve the rights to revise this instruction without any prior notice.

Header Box Fan

IMPORTANT

WARRANTY INFORMATION
ON REVERSE SIDE
DO NOT DISCARD

PURCHASE RECORD FOR YOUR REFERENCE

PLEASE FILL IN THIS CARD PRIOR TO FAN INSTALLATION.
INFORMATION IS MANDATORY IN CASE OF WARRANTY CLAIM.

BRAND:

MODEL NUMBER:

SERIAL/BATCH NUMBER:

DATE OF PURCHASE:

PURCHASED FROM:

INSTALLED BY ELECTRICIAN (IF APPLICABLE)

.....
ELECTRICIAN LICENCE NUMBER (IF APPLICABLE)

.....
If you have any queries about the products, please contact us
(03 9758 7844 or enquiries@partnerpacific.com) or your local dealer.

